



The Facet VF-21SB/22SB can be used as a filter housing. They are versatile, compact, light weight housings and provide superior in-line filtration protection.

Both interior and exterior surfaces of the carbon steel body are epoxy coated to protect against corrosion. This sturdy, single cartridge housing is easy to maintain and requires only 2" (51 mm) base clearance for cartridge change out.

Standard Housing Design

- Body: Carbon steel
- Aluminum Head
- Interior and exterior: Epoxy coated
- Design pressure: 150 psi (10.3 bar)
- Closure: Swing-bolt
- Closure seal: Buna-N o-ring—other materials available upon request
- Vent and drain connections with brass petcocks provided
- Inlet and outlet connections: 1½" NPT female threaded
- One filter cartridge installed

VESSEL OPTIONS

MODEL	DESCRIPTION
VF-21SB	Housing only
VF-21SB-PG	Housing w/ Direct Reading Differential Pressure Gauge
VF-22SB	Housing only
VF-22SB-PG	Housing w/ Direct Reading Differential Pressure Gauge
644160	Mounting Bracket
644964	Grounding Cable

Differential Pressure Gauge - The piston-type differential pressure gauge provides a simple visual warning. When 15 psi (1.03) differential pressure is reached, the gauge indicator moves from green to red zone. This warning will prevent premature cartridge change-out.

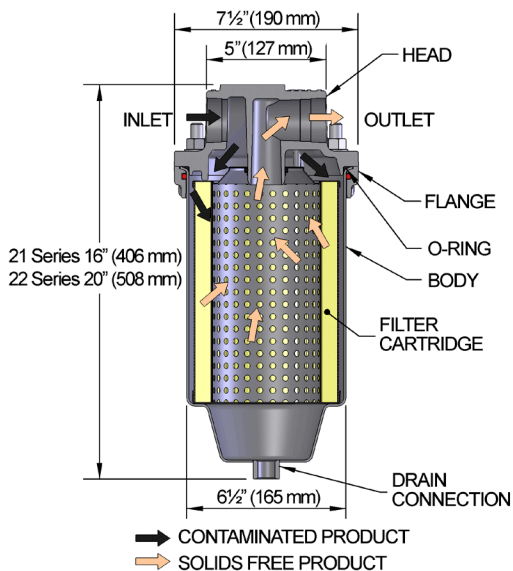

Mounting Bracket (Optional)

ACCORDING TO THE REQUIREMENTS OF EUROPEAN PRESSURE EQUIPMENT DIRECTIVE (PED) 2014/68/EU ART. 4.3, WITHIN THE OPERATING LIMITS PROVIDED ON VESSEL NAMEPLATE AND SUMMARIZED BELOW, THESE FILTERS ARE DESIGNED AND MANUFACTURED IN ACCORDANCE WITH THE SOUND ENGINEERING PRACTICE AND EXEMPT FROM CE MARKING AND CERTIFICATION: 10 BAR(G) @ 35°C FOR AV-GAS AND JET FUEL.

Fuel-Gard® VF-21SB/22SB Filter

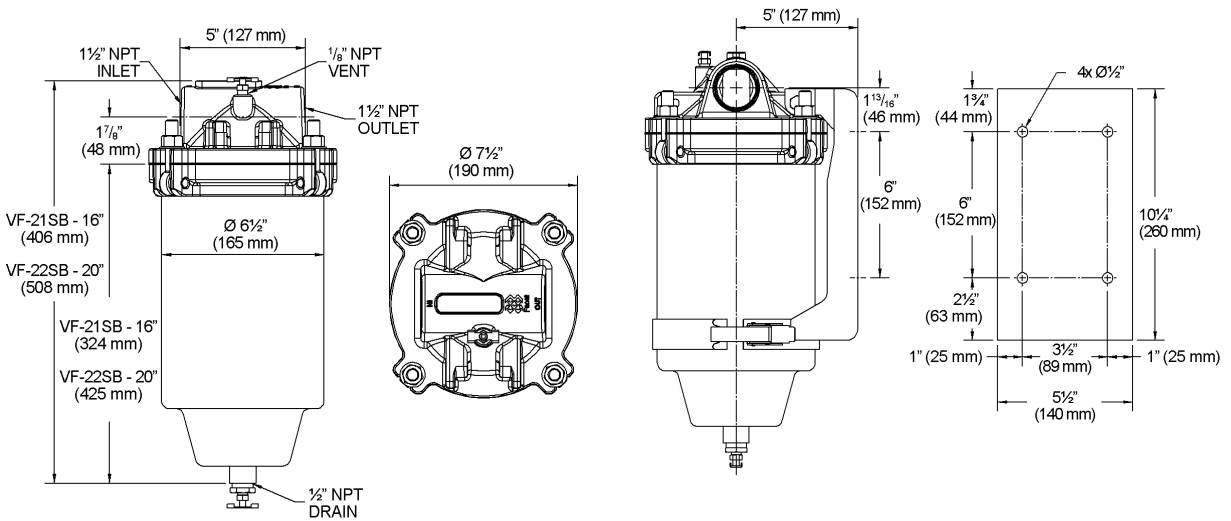



Facet VF-21SB/22SB Series filter cartridges provide long service life and high solids holding capacity with no unloading characteristics. The filter cartridges remove solids.

Standard Design Features

- 2 and 5 Micron Cartridges—other Micron ratings available upon request
- Recommended maximum operating temperature: 240 °F (115 °C)
- Maximum differential pressure: 75 psi (5.17 bar)
- pH range from 5 to 9
- Flow direction: Outside to in

Materials

- Carbon steel structural components
- All metal components coated to protect against corrosion
- Standard gaskets are Buna-N—other materials available on request

DATA

MODEL NUMBER	NOMINAL LENGTH		OUTSIDE DIAMETER		SHIPPING WEIGHT		JET FUEL				AV-GAS			
							INITIAL ΔP		FLOW		INITIAL ΔP		FLOW	
	in	mm	in	mm	lbs	kg	psi	kPa	gpm	lpm	psi	kPa	gpm	lpm
21 Series														
CF-609-2PLO	9	230	6	152	4	1.8	2.1	14.5	45	170	1.2	8.3	45	170
CF-609-5PLO	9	230	6	152	4	1.8	2.1	14.5	45	170	1.2	8.3	45	170
22 Series														
CF-612-2PLO	12	300	6	152	6	2.7	3.1	21.4	60	227	1.6	11.0	60	227
CF-612-5PLO	12	300	6	152	6	2.7	3.1	21.4	60	227	1.6	11.0	60	227

* For applications other than AV-Gas and Jet Fuel, please contact the nearest Facet office.

**DP given for viscosity <2 cSt