

Dust filter cartridge

120 XK

Ø 120 mm, Rd 72x5, temperature-resistant

1. Features

This high-performance dust filter cartridge was developed by Filtration Group for particularly challenging filtration tasks in the chemical and food industries. The conical shape is the outcome of the cartridge's superior flow behaviour and strength. This cartridge design facilitates optimum cleaning in continuous operation in conjunction with a Filtration Group cleaning unit. Typical dust deposits are virtually eliminated by completely filling the end cap on the bottom, because almost all deposits on the cartridge are drained off during cleaning. The key features here are the Filtration Group MJD multi-jet nozzle and pleats supported by wire mesh.

All filter materials used have undergone extensive testing.

Regular, extensive material and performance tests are the key to the consistently high quality of Filtration Group dust cartridges. A team of dedicated engineers in our applications department and modern development laboratories constantly endeavour to mature and perfect our products. Applications tests on the customer's site and in our own facilities form the backbone of affordable and reliable products.

Characteristics

- Improved cleaning properties
- Optimised flow conditions
- High stability
- Installation on the raw gas side
- Worldwide distribution



2. Technical Data

Materials

Inner core:	Stainless steel V4A - 1.4571
End caps:	Stainless steel V4A - 1.4571
Seal:	self-adhesive needle felt* (supplied loose)
Filter material:	DRG 5N - Stainless steel wire mesh 1.4404
	Ti 07/1 - Electrostatical conductive polyester fleece with PTFE membrane
	Ti 18/1 - Polyphenyl sulphide with PTFE Membrane 1100 µm

Cleaning

Nozzle:	Multi-jet nozzle G3/8
Cleaning pressure:	3 bar to 6 bar
Differential pressure:	max. 25 mbar
Compressed air consumption per cleaning pulse:	9 l (fad)
Compressed air reservoir capacity:	approx. 2 l per filter cartridge

* Other sealing systems can be supplied

Technical data is subject to change without notice!

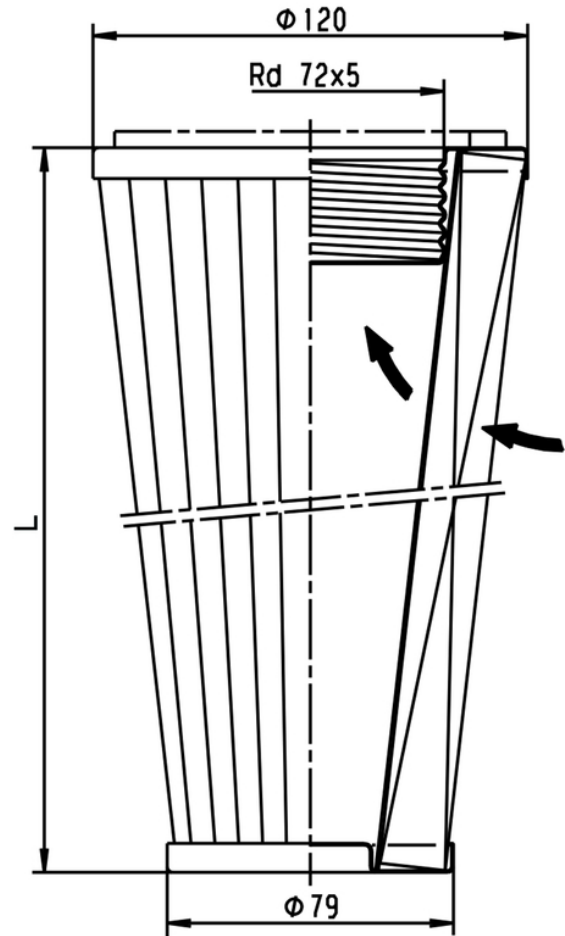

3. Order numbers

Order number	Type designation	Length L [mm]	Filter material	Filter surface [m²]	Max. vol. flow** [m³/h]	Max. operating temperature [°C]	Electr. conductive
76354922	852 902 DRG 5N-0.25 V4A FRV*	300	DRG 5N	0.25	65	130	yes
70324025	852 902 Ti 07-0.25 V4A FRV*		Ti 07/1				
76354633	852 902 Ti 18-0.25 V4A FRV*		Ti 18/1				
79394081	852 903 DRG 5N-0.5 V4A FRV*	600	DRG 5N	0.5	100	240	yes
79748666	852 903 Ti 07-0.5 V4A FRV*		Ti 07/1			130	
76361984	852 903 Ti 18-0.5 V4A FRV*		Ti 18/1			160	
76160311	852 904 Ti 07-0.8 V4A FRV*	982	Ti 07/1	0.8	150	130	yes

* Version made of stainless steel V4A - 1.4571 or equivalent with glued pleat backs

** These values may vary depending on the nature of the dust and the composition of the gas.

4. Installation

The dust filter cartridge can be mounted on and dismantled from the filter plate using the Rd 72x5 thread adapter - no tools required. A hole with a diameter of 80 mm must be drilled in the filter plate in order to mount the thread adapter. The thread adapter should be spot-welded to the filter plate as shown in the drawing. Various adapters are available for installation on the cleaned side or for mating with Rd 60x4 or Rd 74x4 round threads.

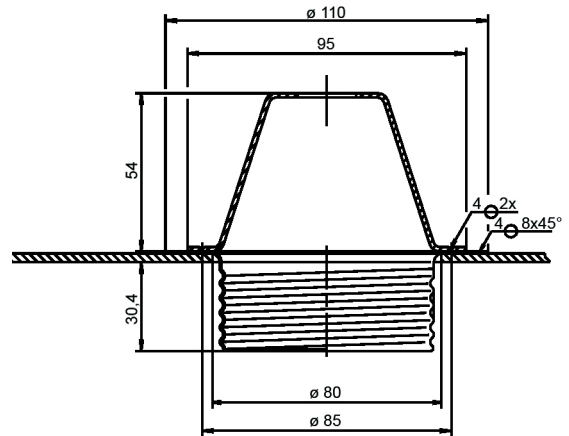
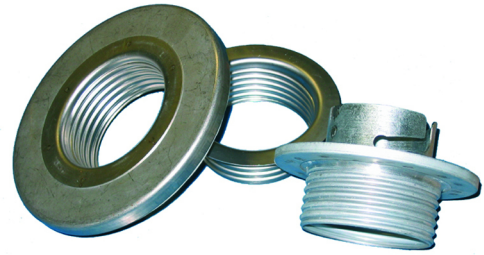

5. Accessories

Order number	Designation
79382318	Thread adapter Rd 72x5, stainless steel V4A - 1.4571
79325234	Nozzle-M12 3/8, stainless steel
76315329	Adapter Rd 60x4/Rd 72x5, stainless steel V4A - 1.4571
79747148	Adapter Rd 73x4/Rd 72x5, stainless steel V4A - 1.4571
76139950	Adapter Rd 74x4/Rd 72x5, stainless steel V4A - 1.4571
78314528	Adapter cleaned gas Rd 72x5, stainless steel V4A - 1.4571

6. Cleaning

We recommend cleaning the dust filter cartridge with the Filtration Group multi-jet nozzle. The optimised geometry of the multi-jet nozzle guarantees excellent cleaning results with a significantly lower noise level.

The multi-jet nozzle is available from Filtration Group in aluminium or stainless steel. It can also be purchased as part of the Filtration Group MJD cleaning unit, comprising the nozzle, a stirrup and various small assembly components. The stirrup maintains an optimum distance from the cartridge to ensure maximum cleaning efficiency.



7. Design

Please contact us for detailed technical information, any open questions and for general expert advice. Completion of the relevant questionnaire would facilitate in the coordination of all important parameters. Comprehensive documentation on our product range, cleaning units and cartridges can be provided.

Filtration Group GmbH
Schleifbachweg 45
D-74613 Öhringen
Phone +49 7941 6466-0
Fax +49 7941 6466-429
fm.de.sales@filtrationgroup.com
www.filtrationgroup.com
70342661.04/2017