

Cartridge filter

AFS12-30

1. Introduction

Specially designed for sterile filter applications we can offer a range of high quality sanitary filter housings in stainless steel. Filtration Group supplies a complete range of filter housings. These housings have proven their quality in the pharmaceutical and beverage industries. For models from 1 up to 8 cartridges, please see Data Sheet AFS1-8.



2. Features

- Compact design
- For 10", 20", 30" or 40" cartridges
- O-ring sealing: standard silicone, FDA / BfR approved
- Vessel material stainless steel 1.4404 (316L)
- Externally mechanically polished
- Tri-clamp closing
- Three adjustable support legs
- One vent connection (1.5" clamp)
- Drain connections optional
- Various instrument configurations possible

Internal finish

Mechanically polished (Ra < 0.8 µm)

On request:

- Internally mechanically polished (Ra < 0.4 µm)
- Electropolishing (internal/external)

3. Standard specifications

Design pressure :

AFS 12	0 / 9 bar(g) at 40 °C 0 / 7 bar(g) at 150 °C
AFS18, 24, 30	0 / 8 bar(g) at 40 °C 0 / 6.2 bar(g) at 150 °C

Test pressure

AFS12	14.5 bar(g)
AFS18, 24, 30	11.5 bar(g)

Design temperature : 0 / 150 °C

Operating pressure : depending on application

Operating temperature : depending on application, filter cartridge and gasket

Design code : AD-Merkblätter

Approval : PED 2014/68/EU

Hazard category : I

Fluid group : 1 and 2



4. Housing data and dimensions

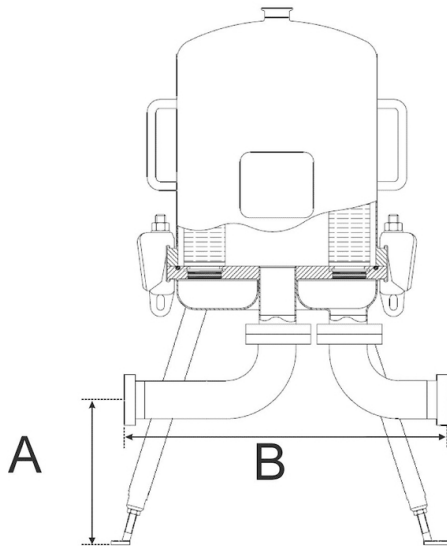

A = Height Inlet / outlet

B = Distance inlet / outlet

5. Housing Data

	Cartridge length	Number of cartridges			
		12	18	24	30
Diameter		350	400	450	500
Total height [mm]	10"	930	950	825	1000
	20"	1180	1200	1075	1250
	30"	1430	1450	1325	1500
	40"	1680	1700	1575	1750
Additional height required for lifting bowl [mm]	10"	290	290	290	290
	20"	540	540	540	540
	30"	790	790	790	790
	40"	1040	1040	1040	1040
Volume [dm ³]	10"	41	54	73	118
	20"	66	85	112	176
	30"	89	115	151	235
	40"	113	146	190	293
Total weight empty [kg]	10"	58	59	85	93
	20"	62	90	63	101
	30"	66	95	68	109
	40"	70	74	100	117
Bowl weight [kg]	10"	10	12	15	28
	20"	14.5	17	20	38
	30"	19	22	25	48
	40"	23	27	30	58



6. Dimensions

Inlet / outlet connections	Weld				DIN 11851 male part				Clamp				
	2.0"	2.5"	3.0"	4.0"	DN50	DN65	DN80	DN100	2.0"	2.5"	3.0"	4.0"	
Height inlet / outlet [mm] A													
12 cartridges	350	326	298	295	350	326	316	295	350	326	298	295	
18 cartridges	-	325	297	292	-	325	310	292	-	325	297	292	
24 cartridges	-	300	272	292	-	300	310	292	-	300	272	292	
30 cartridges	-	300	272	292	-	300	310	292	-	300	272	292	
Distance inlet / outlet [mm] B													
12 cartridges	no drains	449	467	523	483	519	547	535	507	474	493	536	515
	with drains	518	547	603	563	586	627	615	667	544	573	629	594
18 cartridges	no drains	-	524	540	604	-	604	582	604	-	550	566	630
	with drains	-	604	620	580	-	684	662	684	-	630	646	612
24 cartridges	no drains	-	538	554	534	-	618	616	638	-	564	580	566
	with drains	-	618	634	614	-	698	696	718	-	644	660	640
30 cartridges	no drains	-	639	660	630	-	719	712	734	-	665	686	662
	with drains	-	719	740	710	-	800	792	814	-	745	766	742

Dimensions are for reference only. Use dimensional drawing for installation purposes.

Subject to technical alteration without prior notice.

7. Ordering code

Example

AFS12	4	2	B	0	7
Type	Cartridge length	Inlet / outlet size	Inlet / outlet connection	Drain connections	Cartridge style
AFS12 = 12 cartridges	1 = 10" 2 = 20"	2 = 2.0" / DN50 2.5 = 2.5" / DN65	B = weld M = DIN 11851 male part T = clamp	0 = no drains 2 = two drains (clamp 1.5")	7 = X7 and X6 style 8 = X8 and X3 style
AFS18 = 18 cartridges	3 = 30" 4 = 40"	3 = 3.0" / DN80 4 = 4" / DN100			
AFS24 = 24 cartridges		See possible connection sizes in table Dimensions.			
AFS30 = 30 cartridges					