

## Cartridge filter

### AFS1-8

### 1. Introduction

Specially designed for sterile filter applications we can offer a range of high quality sanitary filter housings in stainless steel. Filtration Group supplies a complete range of filter housings. These housings have proven their quality in the pharmaceutical and beverage industries. For models from 12 up to 30 cartridges, please see Data Sheet AFS12-30.



### 2. Features

- Compact design
- For 10", 20", 30" or 40" cartridges
- O-ring sealing: standard silicone, FDA / BfR approved
- Vessel material stainless steel 1.4404 (316L)
- Externally mechanically polished
- Tri-clamp closing
- Three adjustable support legs
- One vent connection (1.5" clamp)
- Drain connections optional
- Various instrument configurations possible

#### Internal finish

Mechanically polished (Ra < 0.8 µm)

On request:

- Internally mechanically polished (Ra < 0.4 µm)
- Electropolishing (internal/external)

### 3. Standard specifications

Design pressure : 0 / 10 bar(g) at 40 °C  
0 / 7.5 bar(g) at 150 °C  
Test pressure : 14.5 bar(g)  
Design temperature : 0 / 150 °C

Operating pressure : depending on application  
Operating temperature : depending on application, filter cartridge and gasket

Design code : AD-Merkblätter  
Approval : PED 2014/68/EU  
Hazard category : I  
Fluid group : 1 and 2



## 4. Housing data and dimensions

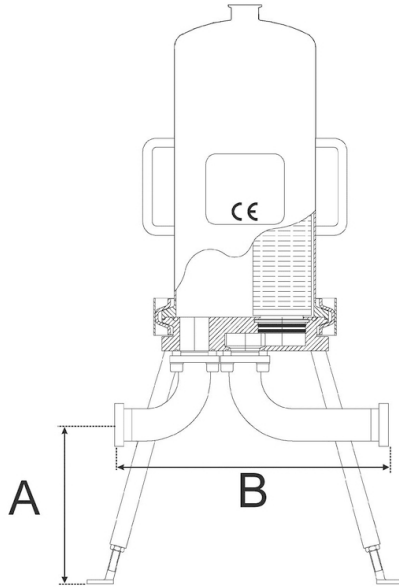

A = Height Inlet / Outlet

B = Distance Inlet / Outlet

## 5. Housing data

|  | Cartridge length | Number of cartridges |      |      |      |
|--|------------------|----------------------|------|------|------|
|  |                  | 1                    | 3    | 5    | 8    |
| Diameter   |                  | 102                  | 169  | 219  | 273  |
| Total height [mm]                                | 10"              | 800                  | 800  | 800  | 800  |
|  | 20"              | 1050                 | 1060 | 1075 | 1096 |
|  | 30"              | 1300                 | 1310 | 1325 | 1346 |
|  | 40"              | 1550                 | 1560 | 1575 | 1596 |
| Additional height required for lifting bowl [mm] | 10"              | 300                  | 290  | 290  | 290  |
|  | 20"              | 550                  | 540  | 540  | 540  |
|  | 30"              | 800                  | 790  | 790  | 790  |
|  | 40"              | 1050                 | 1040 | 1040 | 1040 |
| Volume [dm <sup>3</sup> ]                        | 10"              | 3.0                  | 7.3  | 11.0 | 21.3 |
|  | 20"              | 4.8                  | 12.6 | 20.0 | 35.5 |
|  | 30"              | 6.7                  | 17.8 | 29.1 | 49.7 |
|  | 40"              | 8.6                  | 23.1 | 38.2 | 63.9 |
| Total weight empty [kg]                          | 10"              | 7.0                  | 17.4 | 18.0 | 27.0 |
|  | 20"              | 8.2                  | 19.4 | 22.0 | 30.0 |
|  | 30"              | 9.4                  | 21.4 | 22.0 | 33.0 |
|  | 40"              | 10.6                 | 23.4 | 24.0 | 36.0 |
| Bowl weight [kg]                                 | 10"              | 2.0                  | 4.0  | 5.3  | 7.0  |
|  | 20"              | 3.3                  | 6.0  | 7.5  | 10.0 |
|  | 30"              | 4.6                  | 8.0  | 10.2 | 13.0 |
|  | 40"              | 5.9                  | 10.0 | 12.9 | 16.0 |



## 6. dimensions

| Inlet / Outlet connections | Weld        | DIN 11851 male part |      |      |      |      |      |      |      |      |      | Clamp |      |      |      |      |
|----------------------------|-------------|---------------------|------|------|------|------|------|------|------|------|------|-------|------|------|------|------|
|                            |             | 1.0"                | 1.5" | 2.0" | 2.5" | 3.0" | DN25 | DN40 | DN50 | DN65 | DN80 | 1.0"  | 1.5" | 2.0" | 2.5" | 3.0" |
| [mm]                       |             | 381                 | 340  | 310  | 281  | 253  | 381  | 340  | 310  | 281  | 253  | 381   | 340  | 310  | 281  | 253  |
| 1 cartridge                | no drains   | 163                 | -    | -    | -    | -    | 221  | -    | -    | -    | -    | 189   | -    | -    | -    | -    |
|                            | with drains | 244                 | -    | -    | -    | -    | -    | -    | -    | -    | -    | 270   | -    | -    | -    | -    |
| 3 cartridges               | no drains   | -                   | 285  |      |      |      |      | 351  |      |      |      |       | 310  |      |      |      |
|                            | with drains | -                   | 360  |      |      |      |      | 426  |      |      |      |       | 385  |      |      |      |
| 5 cartridges               | no drains   | -                   | 305  | 353  |      |      |      | 371  | 423  |      |      |       | 331  | 379  |      |      |
|                            | with drains | -                   | 380  | 420  |      |      |      | 446  | 490  |      |      |       | 406  | 446  |      |      |
| 8 cartridges               | no drains   | -                   | 331  | 379  | 442  | 498  | -    | 379  | 449  | 518  | 588  | -     | 357  | 405  | 469  | 524  |
|                            | with drains | -                   | 406  | 446  | 522  | 578  | -    | 472  | 516  | 602  | 658  | -     | 432  | 472  | 548  | 604  |

Dimensions are for reference only. Use dimensional drawing for installation purposes.

Subject to technical alteration without prior notice.

## 7. Ordering code

Example

| AFS3                | 4                | 2                   | B                         | 0  | 7                   |
|---------------------|------------------|---------------------|---------------------------|--|---------------------|
| Type                | Cartridge length | Inlet / outlet size | Inlet / outlet connection | Drain connections                              | Cartridge style     |
| AFS1 = 1 cartridge  | 1 = 10"          | 1 = 1.0" / DN25     | B = weld                  | 0 = no drains                                  | 7 = X7 and X6 style |
| AFS3 = 3 cartridges | 2 = 20"          | 1.5 = 1.5" / DN40   | M = DIN 11851 male part   | 2 = two drains (clamp 1.5", for AFS1 clamp 1") | 8 = X8 and X3 style |
| AFS5 = 5 cartridges | 3 = 30"          | 2 = 2.0" / DN50     | T = clamp                 |  |                     |
| AFS8 = 8 cartridges | 4 = 40"          | 2.5 = 2.5" / DN65   |                           |  |                     |
|                     |                  | 3 = 3.0" / DN80     |                           |  |                     |